

Garlock 104GS

General service elastomeric expansion joint

General service expansion joints must withstand a variety of different operating conditions across multiple industries. The 104GS from Garlock is designed to handle these most common requirements, and more. Although competitively priced, the 104GS has been rigorously tested to insure it provides the same quality and consistency you expect from Garlock products.

Standard construction features a neoprene tube and cover that offer a wide range of media compatibility making the 104GS an ideal general service expansion joint. The high strength nylon fabric reinforcement combined with carbon steel support rings and body wire enable the 104GS to withstand some of the most demanding system requirements regardless of industry.

The 104GS is available in stock sizes 2" thru 24" ID and is sold complete with galvanized carbon steel retaining rings. The large in stock quantities and standard face-to-face dimensions make this product ideal for plant expansions and new construction projects.



Value & Benefits

- The versatility of the neoprene tube ¹ and cover ⁴ make the 104GS ideally suited for most general service industrial applications.
- Reinforcement materials of nylon fabric ⁵ combined with carbon steel body wire ³ and support rings ² allow the 104GS to withstand significant operating pressures and 26" Hg vacuum for all sizes.
- The wide, single arch ⁶ design allows for greater movements and helps to reduce the affects of moderate sediment transfer.
- Available in 2" thru 24" and sold complete ⁷ with galvanized carbon steel retaining rings simplifying the order process.

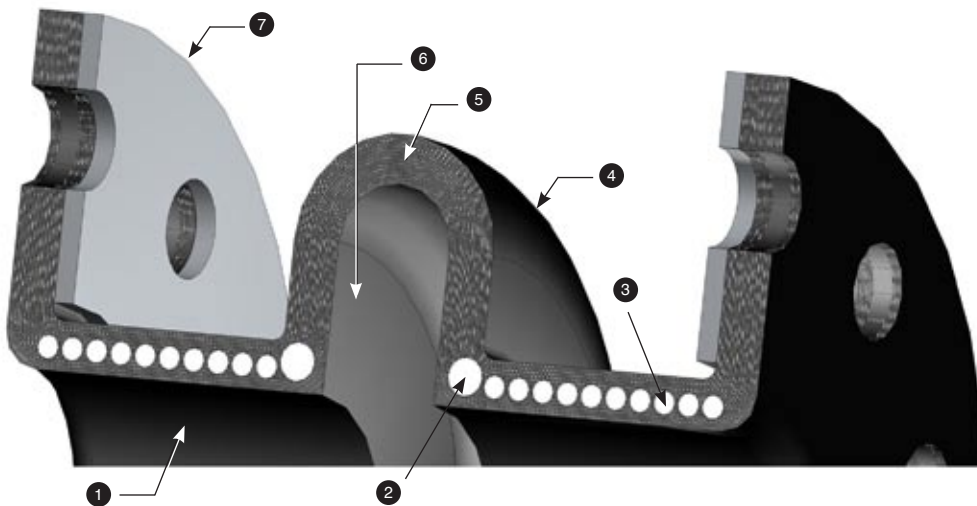

Garlock

SEALING TECHNOLOGIES®

an EnPro Industries company

Specifications - 200°F Maximum Temperature Rating

Expansion Joint				Application Data				Movement Ratings							
Size I.D.		Face-to-Face		Pressure		Vacuum		Compression		Lateral		Elongation		Angular Degrees	Torsional Degrees
Inch	mm	Inch	mm	psi	bar	Inch Hg	mm Hg	Inch	mm	Inch	mm	Inch	mm		
2	50	6	150	195	13	26	660	1-1/4	32	3/4	19	1/2	13	10	3
3	75	6	150	195	13	26	660	1-1/4	32	3/4	19	1/2	13	8	3
4	100	6	150	195	13	26	660	1-1/4	32	3/4	19	1/2	13	6	3
5	125	6	150	165	11	26	660	1-3/8	35	1	25	5/8	16	8	3
6	150	6	150	165	11	26	660	1-3/8	35	1	25	5/8	16	7	3
8	200	6	150	165	11	26	660	1-3/8	35	1	25	5/8	16	5	3
10	250	8	200	165	11	26	660	1-3/8	35	1	25	5/8	16	5	3
12	300	8	200	165	11	26	660	1-1/2	38	1	25	3/4	19	5	3
14	350	8	200	100	7	26	660	1-1/2	38	1	25	3/4	19	4	2
16	400	8	200	75	5	26	660	1-1/2	38	1	25	3/4	19	4	2
18	450	8	200	75	5	26	660	1-1/2	38	1	25	3/4	19	3	1
20	500	8	200	75	5	26	660	1-1/2	38	1	25	3/4	19	3	1
24	600	10	250	75	5	26	660	1-3/4	44	1	25	1	25	4	1

Expansion Joint Size I.D.		ANSI Class 150 Flange Drilling						No. of Bolt Holes	Spring Rates						Bolt Torque
		OD		Bolt Circle		Bolt Hole Diameter			Compression		Lateral		Elongation		
		Inch	mm	Inch	mm	Inch	mm		lb/inch	kg/mm	lb/inch	kg/mm	lb/inch	kg/mm	
2	50	6	152	4-3/4	121	3/4	19	4	450	18	340	13	560	22	40
3	75	7-1/2	191	6	152	3/4	19	4	670	26	500	20	828	15	65
4	100	9	229	7-1/2	191	3/4	19	8	900	35	730	29	1104	20	45
5	125	10	254	8-1/2	216	7/8	22	8	1120	44	900	35	1376	25	50
6	150	11	279	9-1/2	241	7/8	22	8	1400	55	1060	42	1652	30	55
8	200	13-1/2	343	11-3/4	298	7/8	22	8	1510	59	1180	46	1837	33	85
10	250	16	406	14-1/4	362	1	25	12	1900	75	1460	57	2296	41	80
12	300	19	483	17	432	1	25	12	2300	91	1740	69	2755	50	115
14	350	21	533	18-3/4	476	1-1/8	29	12	2010	79	1570	62	2755	50	145
16	400	23-1/2	597	21-1/4	540	1-1/8	29	16	2300	91	1740	69	2755	50	135
18	450	25	635	22-3/4	578	1-1/4	32	16	2570	101	1960	77	3101	56	140
20	500	27-1/2	699	25	635	1-1/4	32	20	2860	113	2180	86	3440	62	135
24	600	32	813	29-1/2	749	1-3/8	35	20	3420	135	2630	104	4130	74	190

Pressure ratings are based on maximum design temperature of 200°F.

Pressure ratings are based on a minimum 3 to 1 safety factor at maximum design temperature.

AUTHORIZED REPRESENTATIVE

WARNING:

Properties/applications shown throughout this brochure are typical. Your specific application should not be undertaken without independent study and evaluation for suitability. For specific application recommendations consult Garlock. Failure to select the proper sealing products could result in property damage and/or serious personal injury. Performance data published in this brochure has been developed from field testing, customer field reports and/or in-house testing.

While the utmost care has been used in compiling this brochure, we assume no responsibility for errors. Specifications subject to change without notice. This edition cancels all previous issues. Subject to change without notice.

GARLOCK is a registered trademark for packings, seals, gaskets, and other products of Garlock.

© Garlock Inc 2006. All rights reserved worldwide.

Garlock

SEALING TECHNOLOGIES®

an EnPro Industries company

Garlock Sealing Technologies
1666 Division Street
Palmyra, New York 14522 USA
1-315-597-4811
1-800-448-6688
Fax: 1-800-543-0598
1-315-597-3039

www.garlock.com

Other Garlock facilities are located in:

Columbia, SC, USA
 Phone 1.803.783.1880
 Fax 1.803.783.4279

São Paulo, Brazil
 Phone 55.11.4352.6161
 Fax 55.11.4352.8181

Saint-Étienne, France
 Phone 33.4.7743.5100
 Fax 33.4.7743.5151

Singapore
 Phone 65.6285.9322
 Fax 65.6284.5843

Houston, TX, USA
 Phone 1.281.459.7200
 Fax 1.281.458.0502

Sherbrooke, Canada
 Phone 1.819.563.8080
 Fax 1.819-563.5620

Neuss, Germany
 Phone 49.2131.3490
 Fax 49.2131.349.222

Shanghai, China
 Phone 86.021.62789702
 Fax 86.021.62787826

Sydney, Australia
 Phone 61.2.9793.2511
 Fax 61.2.9793.2544

W. Yorkshire, England
 Phone 44.1422.313600
 Fax 44.1422.313601

Mexico City, Mexico
 Phone 52.555.567.7011
 Fax 52.555.368.0418

Dubai, UAE
 Phone 971.4.8833652
 Fax 971.4.8833682